



Sonic Installation Manual Air Knife



**Sonic Air Systems
1050 Beacon Street
Brea, California 92821
Tel: 714-255-0124 Fax: 714-255-8366
www.sonicairsystems.com**



Sonic Installation Manual

SIM-001

Air Knife

Release Date: September 24, 2001

Prepared by: _____
Jeff Johnson

Approved by: _____
Mike Pankey

Approved by: _____
Terry Riley

Approved by: _____
Dan VanderPyl

*This document has an electronic master, which resides in the Document Control System (DCS).
The authorizing signatures are on a hard copy of this document held by Document Control.*

Revision Log

Rev. Ltr.	Rel. Date	Chg Req.	Description
New	08/27/01	N/A	Initial Release
A	09/24/01	-	Revise Figure 9, 11, 12
B	02/25/03	-	Revise Address

Table of Contents

1	Introduction.....	2
2	Sonic Air Knives.....	2
2.1	What is an Air Knife?.....	2
2.2	Sonic XE Air Knife.....	2
2.3	Sonic Round Tube Air Knife.....	3
2.4	Air Knife Variations.....	4
3	Air Knife Mounting Instructions.....	5
3.1	Required Tools.....	5
3.2	Mounting Procedure.....	5
3.3	Air Knife Adjustments.....	8
4	Modifying the Air Knife Gap.....	11
4.1	Required Tools.....	11
4.2	Sonic Aluminum XE Gap Adjustment Procedure.....	12
4.3	Sonic Stainless Steel XE Gap Adjustment Procedure.....	13
5	Troubleshooting.....	14
6	Installation Review.....	15

Table of Figures

Figure 1 - Sonic XE Aluminum Air Knife.....	3
Figure 2 - Sonic Round Tube Air Knife.....	4
Figure 3 - Inlet Variations.....	5
Figure 4 – Standard.....	6
Figure 5 - Dual Inlet.....	7
Figure 6 - Middle Inlet.....	8
Figure 7 – Sonic Chevron Bracket (w/ Air Knives).....	8
Figure 8 - Mounting Variations.....	8
Figure 9 - Air Knife Positioning - Front View.....	9
Figure 10 - Air Knife Positioning - Side & Top View.....	10
Figure 11 - Air Knife Installation - Side View.....	11
Figure 12 - Air Knife Installation - Front View.....	11
Figure 13 - Loosen Endcaps.....	12
Figure 14 - Loosen Adjustment Screws.....	12
Figure 15 - Adjust Gap.....	12
Figure 16 - Verify Gap Setting.....	13
Figure 17 - Loosen Adjustment Screws.....	13
Figure 18 - Adjust Gap Setting.....	13

Table of Tables

Table 1 - Distance vs. Airflow.....	5
Table 2 - Air Knife Bracket Selection.....	5
Table 3 - Aluminum Sonic XE Tool List.....	11
Table 4 - Stainless Steel Sonic XE Tool List.....	12
Table 5 - Troubleshooting.....	14

1 Introduction

Sonic Air Systems is the industry leader in engineered drying solutions and the air knife is an integral part of many of these drying solutions. This manual is intended to:

- Identify the product
- Provide installation guidance and recommendations
- Familiarize personnel with the air knife and expected maintenance

2 Sonic Air Knives

2.1 What is an Air Knife?

An air knife is an air delivery tool that provides a continuous laminar air stream that may be utilized for many applications. Typical uses include: drying, product removal, air curtains, etc. The design and shape of the air knife determines the overall exit air efficiency and therefore the ability to solve a particular application.

The slot (air exit point) width and the effective slot length are typically the only required parameters for an air knife. The plenum (internal shape and volume) also contributes to the efficiency of the system.

Air knives used for drying, cleaning or material removal accomplish their work in a two-stage process: First, a high velocity air stream is directed to roll the liquid or material back, creating a standing wave at the point of shear and leaving a thin, residual layer.

Second, as the "point of impact" of the impinging airflow passes over the residual layer, this layer (if liquid) is shattered or atomized to form minute liquid droplets, which are carried away by the air stream to leave a clean, dry surface. Non-liquids are also removed in this second phase.

Air knives may utilize temperature or air pressure to provide further evaporation, cooling, heating, curing or coating control ability. Each system is designed taking into consideration the exact material characteristics and processing requirements of the application involved.

Sonic air knives are powered by Sonics' centrifugal blowers which provide a high cfm / low pressure air supply. Typical pressure requirements for drying applications are from 1 psig to 4 psig (0.07 to 0.28 bar) and therefore the Sonic system is the ideal solution for any drying system.

2.2 Sonic XE Air Knife

The Sonic Aluminum (See Figure 1) and Stainless Steel XE Air Knife designs are engineered profile plenum assemblies providing the maximum efficiency available for high velocity air knife drying applications. The air knife assemblies are manufactured in

lengths of 2” to 192” (51mm to 4,877mm). A Sonic Centrifugal Blower is used to power the air knives and deliver air up to 42,000 fpm (12,800 mpm). As compared to the traditional round tube air knife design, the Sonic XE Air Knife increases exit velocities as much as 50 percent and provides an improved discharge effectiveness.

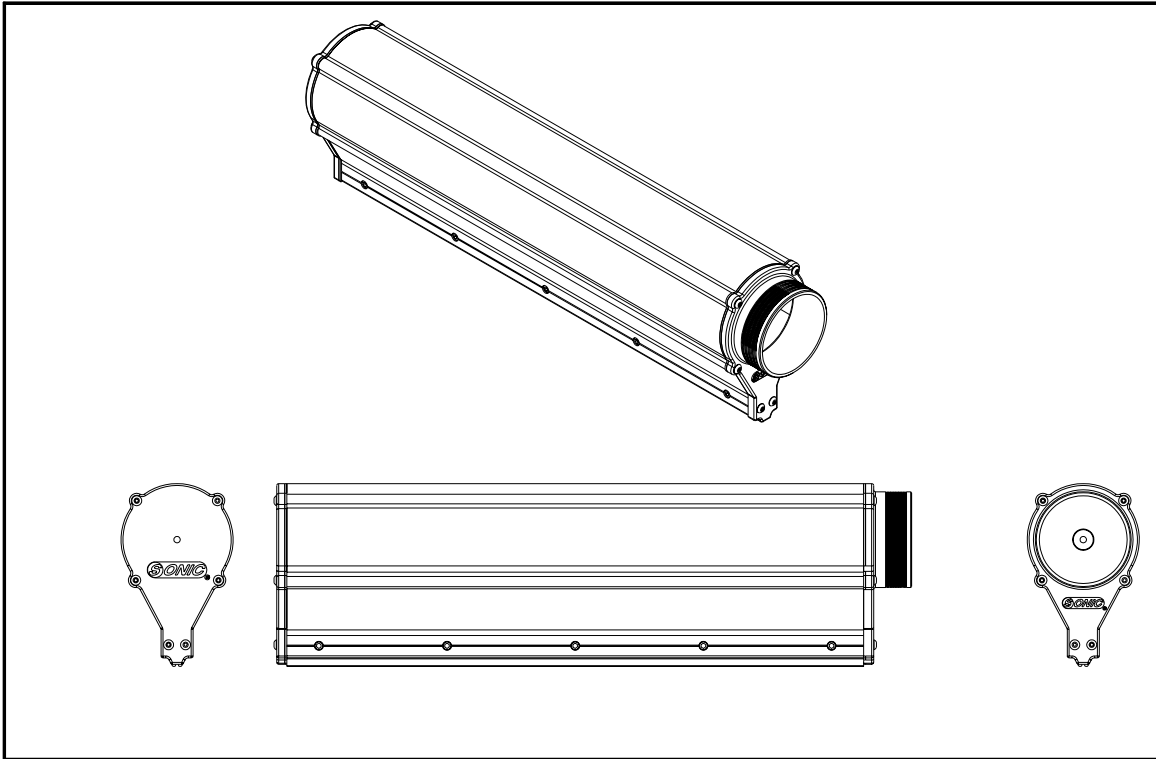

Figure 1 - Sonic XE Aluminum Air Knife

The design criteria of the Sonic XE are based on providing a highly concentrated air stream to impact the product surface. Exit velocities ranging from 20,000 fpm (6,100 mpm) to 42,000 fpm (12,800 mpm) are utilized to provide the energy at the point of contact. The air exits as an uninterrupted continuous curtain with a totally controlled pattern. This stability guarantees minimal surrounding air excitation on the downstream leg and a narrow pattern on the upstream end.

The Sonic XE Air Knife features the following:

- Available in 6063 aluminum or 316 stainless steel
- 2” or 3” inlet diameter
- At pressures of 100” of H₂O (0.28 bar), provides drying capacity comparable to round tube air knife at 25% less horsepower.
- Continuous uninterrupted air slot design. Slot settings are 0.025 to 0.125 inches (0.6 to 3.2 mm) typically.
- Sonic stocks multiple lengths of air knives but custom length and design air knives are available upon request.

2.3 Sonic Round Tube Air Knife

The round tube air knife, typically a tube or pipe with a slot machined along the length, is the classic design. A round tube air knife has good internal flow characteristics and provides a relatively large laminar flow area. The exit slot in this design typically has a low efficiency due to poor flow characteristics. Some negative characteristics are: significant pressure loss, turbulence at the slot, air exiting tends to immediately tear and fan out, surrounding air excitation, and relatively fast velocity deterioration.

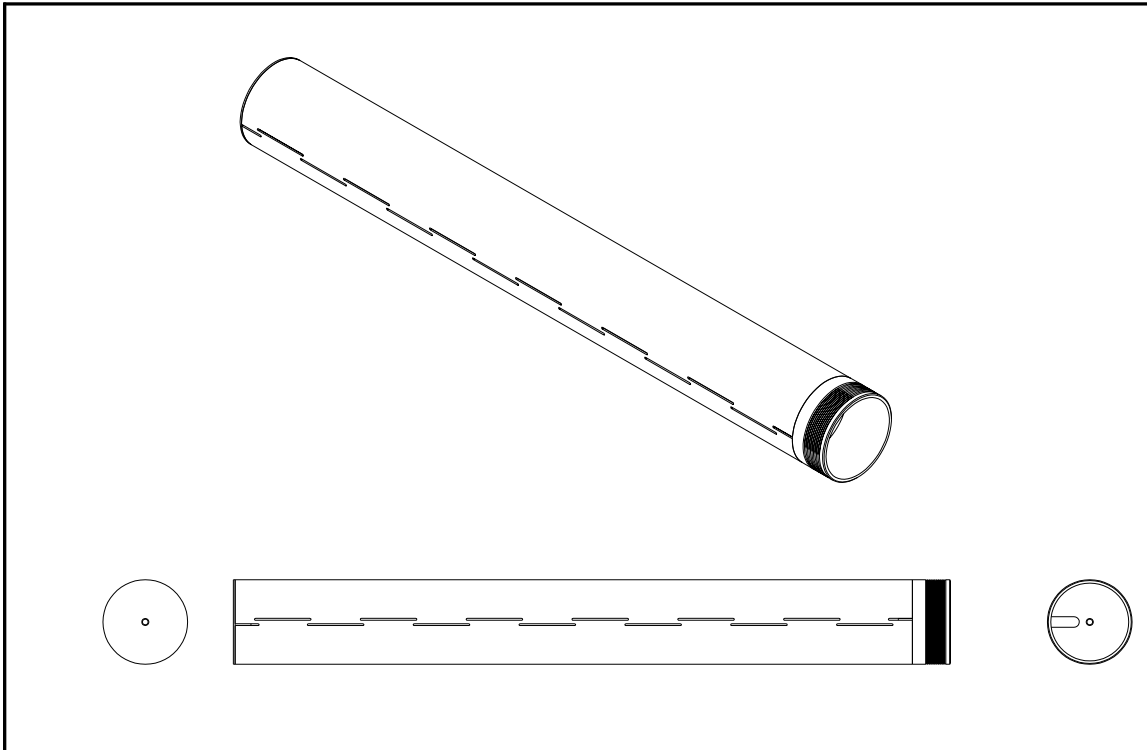

Figure 2 - Sonic Round Tube Air Knife

Although the Sonic XE Air Knife is the most efficient solution to most applications, the Sonic Round Tube Air Knife (See Figure 2) is a preferred solution for many special applications. The round profile is ideal for applications with space restrictions. The design and construction of this air knife also make it ideal for sterile or food applications.

The Sonic Round Tube Air Knife features the following:

- All 304 stainless steel construction
- 2", 3", or 4" inlet diameter
- Optional welded construction

2.4 Air Knife Variations

Standard XE air knives are equipped with a single end inlet standard for the air delivery. Sonic recommends upgrading to a dual inlet system when the airflow to each air knife is greater than 600 cfm (285 lps). Middle inlet and multiple middle inlet air knives are also available to accommodate installations with space restrictions or when multiple inlets are necessary. Figure 3 shows some of the many variations that are possible with a Sonic air knife. Contact Sonic if the variation that is needed is not shown in this figure.

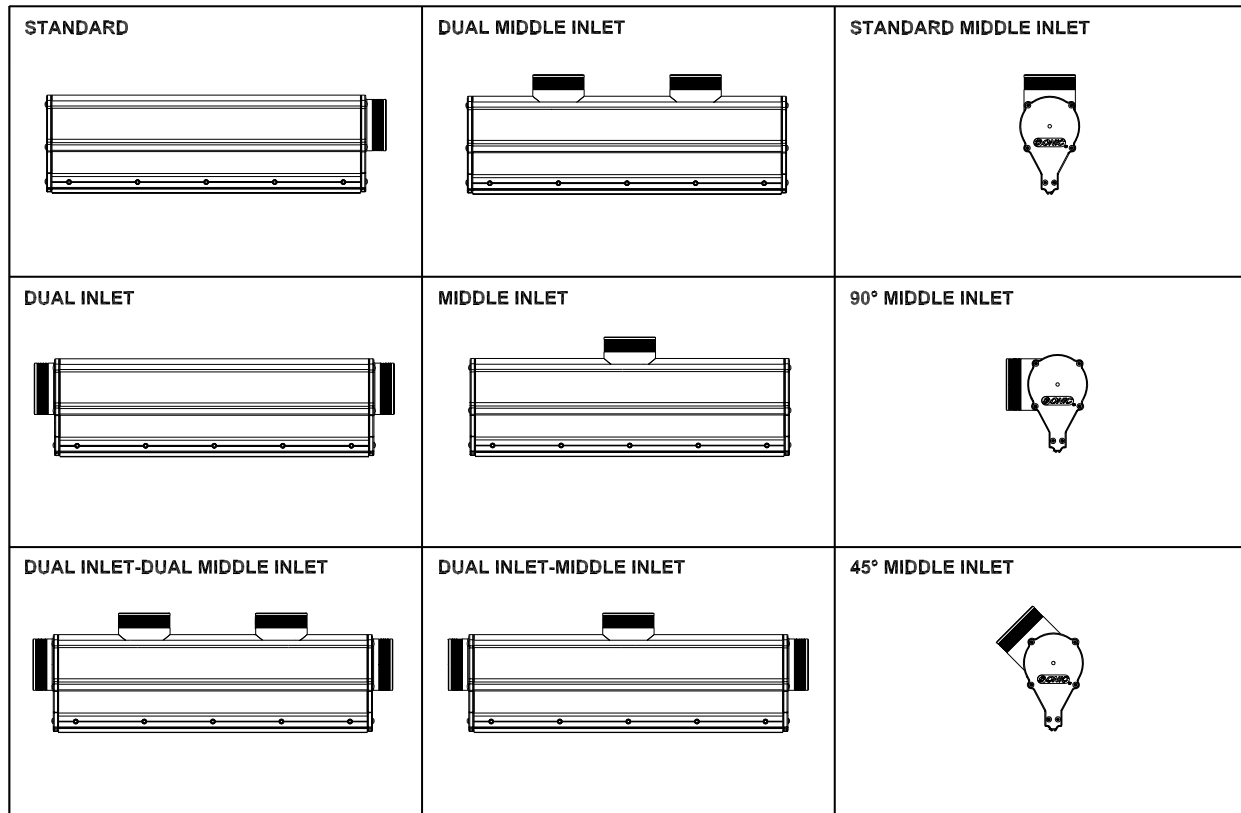

Figure 3 - Inlet Variations

3 Air Knife Mounting Instructions

Standard Sonic air knives come equipped with a 1/4-20 threaded hole on the end cap for mounting purposes. Sonic uses a ring plate and the mounting sleeve and clamp to mount the inlet end cap. The following procedure is designed to illustrate how to mount the Sonic air knives using Sonic air knife mounting brackets. Alternative methods of mounting hardware may be used in place of the Sonic mounting brackets and the general orientation instructions will still be valid.

Sonic designs each system to optimize electrical efficiency and drying performance. The effective gap size has been selected by Sonics' application engineers for each application and therefore should not have to be field adjusted. The following procedures are intended to

show typical installation and modifications of the air knife system. Contact Sonic if these procedures do not apply to the application or if the required performance is not achieved.

3.1 Required Tools

Description	Qty.	Description	Qty.
3/16 inch allen wrench	1	9/16 inch open-end wrench	2
7/16 inch open-end wrench	1		

3.2 Mounting Procedure

1. The air knife exit has to be mounted as close to the product as possible for safe line operation. For conveyor applications, this will require a modification to the guide rails. In most instances, a section of the guide rail will have to be cut and removed to allow the air knife to be placed close to the product. A gap in the guide rail is also required to allow the air to pass unimpeded to the product. The distance of the air knife exit to the product dictates the pressure and airflow required to produce the required effect. The farther the air knife is from the product, the higher the airflow rate and therefore the need for a larger air source (blower) and a significant increase in required horsepower. The following table shows typical guidelines to use to determine air consumption versus distance to product.

Table 1 - Distance vs. Airflow

Distance to Product	Required Airflow
1/4-1/2 inch (6-13 mm)	9.7 cfm / inch (1.8 lps / cm)
1/2-2 inch (13-50 mm)	11.3 cfm / inch (2.1 lps / cm)
2-4 inch (50-100 mm)	15.3 cfm / inch (2.9 lps / cm)
4-8 inch (100-200 mm)	25.3 cfm / inch (4.7 lps / cm)

Table 1 is based on an effective system pressure of 2 psig (0.14 bar), variations in system pressure will increase or decrease the required airflow accordingly (higher pressure requires higher airflow). The airflow is determined from the system pressure and the air knife gap. Sonic designed and set the air knife gap for each application, do not adjust the air knife gap without consulting Sonic.

2. The Sonic mounting bracket has to be solidly mounted to a fixed surface using the provided hardware. Table 2 lists the available mounting brackets and the respective air knife inlet configuration.

Table 2 - Air Knife Bracket Selection

Air Knife Bracket	Bracket P/N
2" Air Knife	12769
3" Air Knife	12665
3" Air Knife w/ Extended Tubes	12662
3" Dual Inlet	12737
2" or 3" Middle Inlet	12738
Chevron	12930

Figure 4, Figure 5, Figure 6 and Figure 7 illustrate the different mounting brackets offered by Sonic. The Sonic universal support brackets are designed for the support of a wide variety of air knives including single inlet, dual inlet, and middle inlet versions. Figure 8 illustrates many of the possible configurations that the Sonic Air Knife may be mounted to a conveyor.

These brackets feature all 304 series stainless steel construction with easy to install common size screw connectors to minimize the number of tools required to assemble. The unique design of these brackets allows for quick adjustment to accommodate multiple positions with no binding of the parts. The chevron bracket is typically used to span a high-speed horizontal conveyor system. By forming a "V" against the product flow, this configuration directs the water to the sides and eliminates standing water buildup.

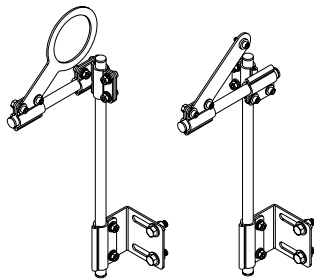

Figure 4 – Standard

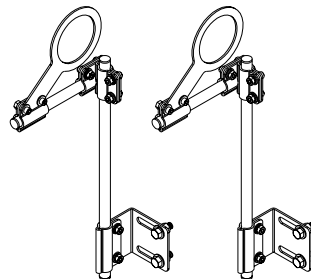

Figure 5 - Dual Inlet

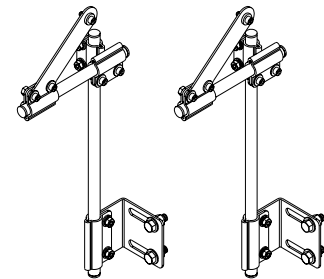

Figure 6 - Middle Inlet

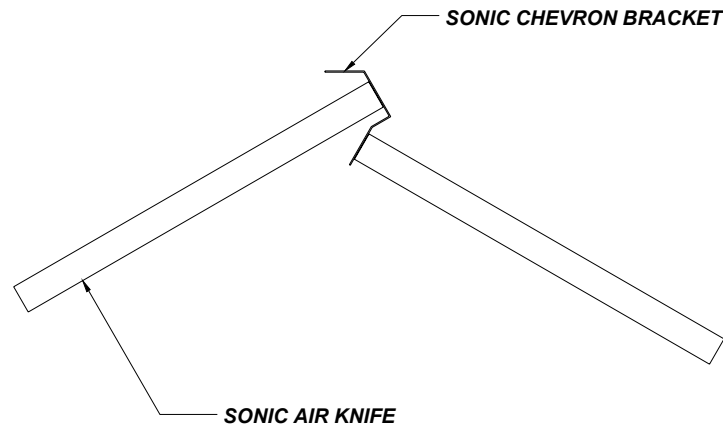

Figure 7 – Sonic Chevron Bracket (w/ Air Knives)

3.3 Air Knife Adjustments

Once the air knife brackets are securely mounted, the air knife must be adjusted to optimize performance. Figure 8 shows some of the many possible variations for mounting an air knife. The final position of the air knife is determined by the function that it serves. The following procedure describes some of the common guidelines, additional adjustments, or modifications that may be necessary.

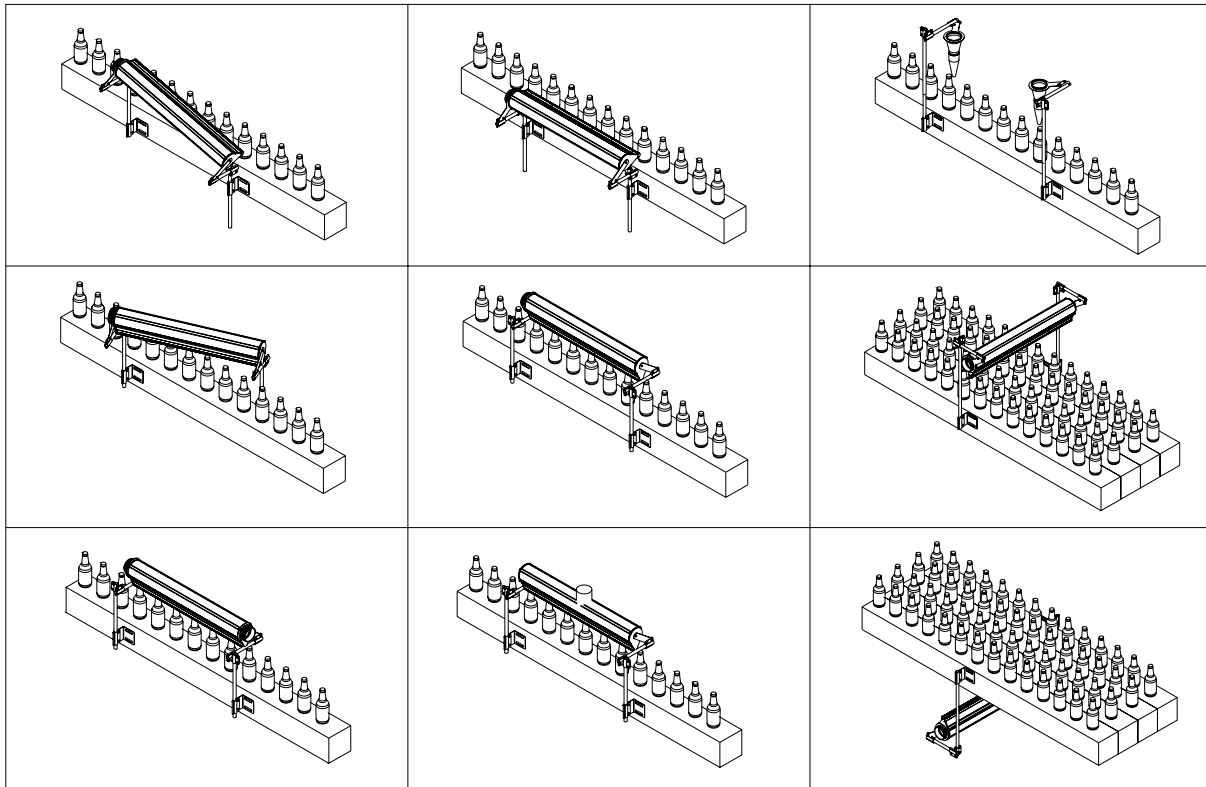

Figure 8 - Mounting Variations

Figure 9 and Figure 10 illustrate the mounting position of the air knives. These figures show a typical can conveyor line that is drying the sides and top of the can. This is only a typical representation, the product and conveyor may vary but the air knife position should be universal. The side air knives must be located as close to the product as possible. As shown, the side guide rails must be cut to allow airflow to contact the product unimpeded. The angle of the side air knives is dependent on the length of the air knife and the height of the product. As shown in Figure 9, the air knife effective slot should extend $\frac{1}{2}$ inch (12 mm) above the product top to assure 100% contact with the product. On the low side of the product, the air knife slot should also be positioned $\frac{1}{2}$ inch (12 mm) above the conveyor to prevent depositing water back upon the product. As shown in Figure 10, the side air knives should be staggered by approximately 1.5 inches (38 mm). This 1.5 inch (38 mm) staggering is required to assure front and trailing edge drying as well as providing opposing forces to maintain product position. As seen in Figure 9, an approximate 10° downturn of the air knives is recommended to force the direction of water down the product. The side air knives should be mounted in reference to the product direction as shown in Figure 10. This forces the water from the top of the product to the bottom of the

product. The top air knife should be mounted before the side air knives to prevent re-depositing the water on the sides of the can.

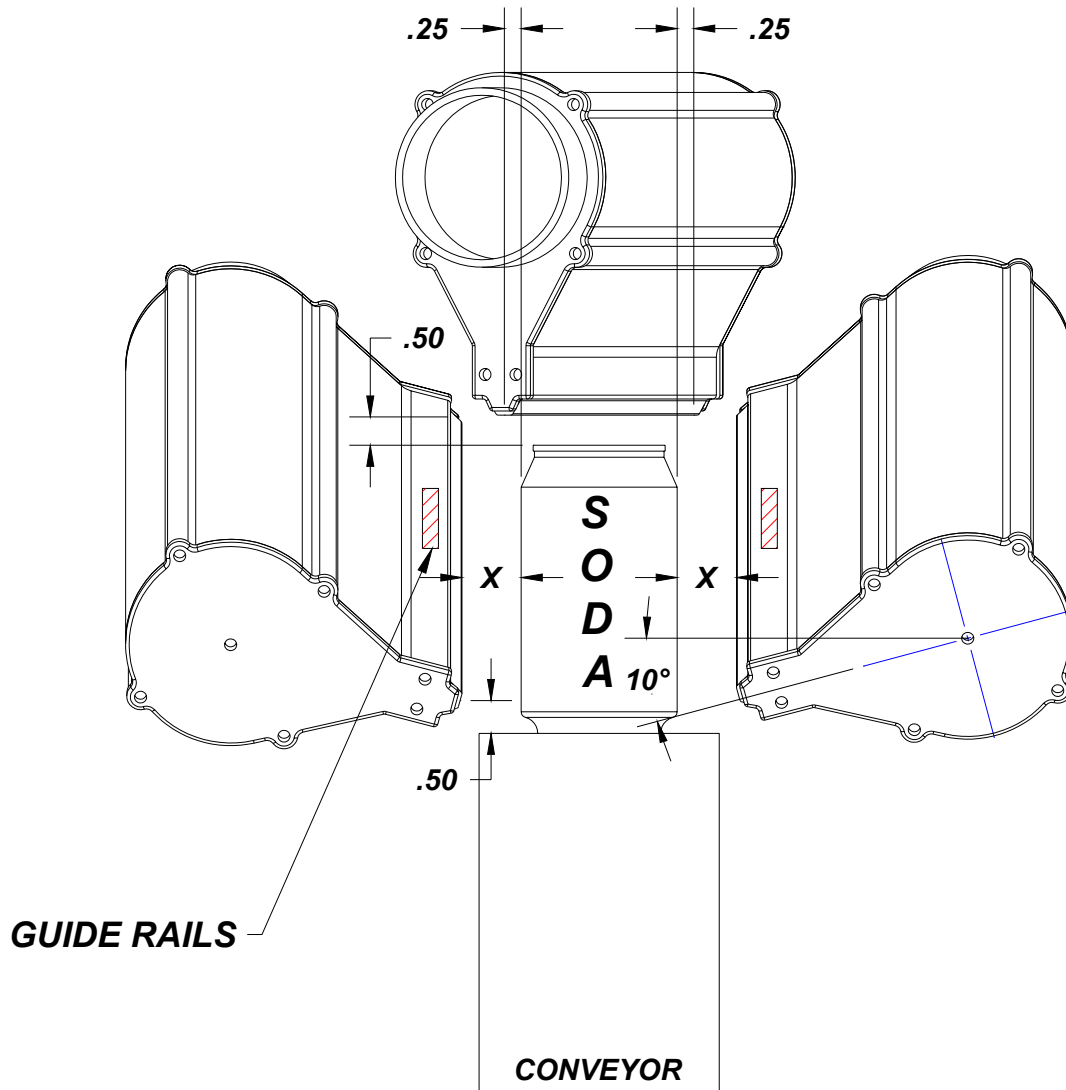

Figure 9 - Air Knife Positioning - Front View

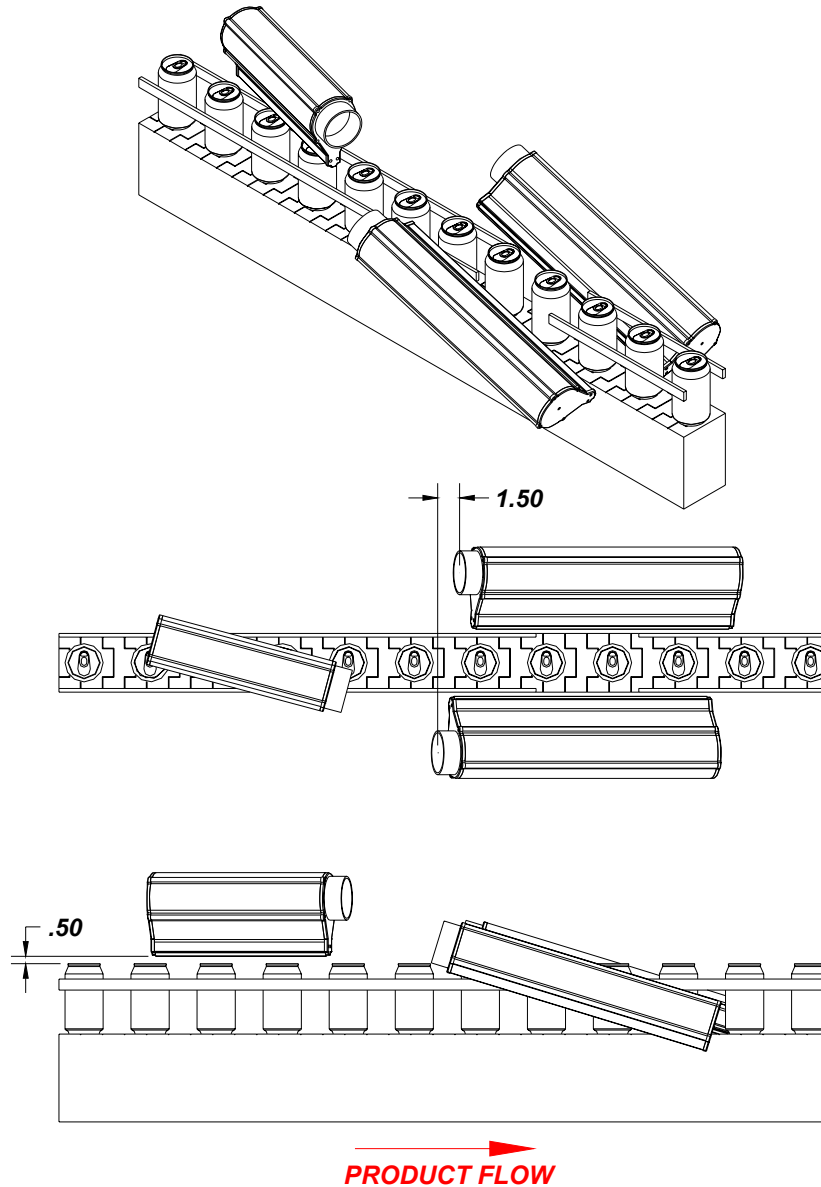

Figure 10 - Air Knife Positioning - Side & Top View

Figure 11 and Figure 12 are photos of a typical air knife installation. These photos show the required orientation and position of the (3) air knife system. As shown, the side rails of the conveyor were cut and the air knives positioned within the gaps. The 1.5 inch (38 mm) staggering of the side air knives is also shown clearly in Figure 11 and Figure 12. These figures also show the Sonic air knife mounting brackets and how they are properly used to mount an air knife to an existing conveyor system.



Figure 11 - Air Knife Installation - Side View



Figure 12 - Air Knife Installation - Front View

4 Modifying the Air Knife Gap

Although Sonic designed and set the gap of the air knife at the factory, it may be necessary to modify the gap. The following procedure describes the process of modifying the gap.

4.1 Required Tools

Table 3 - Aluminum Sonic XE Tool List

Description	Qty.	Description	Qty.
Feeler gauge	1	3/32 inch allen wrench	1
T25 safety torx bit w/ handle	1		

Table 4 - Stainless Steel Sonic XE Tool List

Description	Qty.	Description	Qty.
Feeler gauge	1	5/64 inch allen wrench	1
5/16 inch nut driver	1		

4.2 Sonic Aluminum XE Gap Adjustment Procedure

1. Using the 3/32 inch allen wrench, loosen the button head cap screws on the inlet and end cap. Do not remove completely. (See Figure 13)
2. Using the T25 safety torx bit with handle, loosen the gap adjustment screws. (See Figure 14)
3. Using the T25 safety torx bit with handle and the feeler gauge, adjust the gap at each adjustment screw. (See Figure 15)
4. Using the feeler gauge, verify that the gap along the air knife length. (See Figure 16)
5. Using the 3/32 inch allen wrench, tighten the button head cap screws.



Figure 13 - Loosen Endcaps

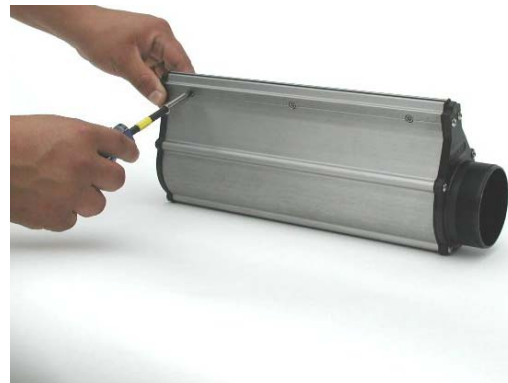

Figure 14 - Loosen Adjustment Screws



Figure 15 - Adjust Gap



Figure 16 - Verify Gap Setting

4.3 Sonic Stainless Steel XE Gap Adjustment Procedure

1. Using the 5/16 inch nut driver, loosen the 6-32 hex nuts.
2. Using the 5/64 allen wrench, loosen all the adjustment screws. (See Figure 17)
3. Using the 5/64 allen wrench and the feeler gauge, adjust the gap setting to the desired amount. (See Figure 18)
4. Using the 5/16 inch nut driver, tighten the nuts.
5. Using the feeler gauge, verify that the gap is set to the correct amount.



Figure 17 - Loosen Adjustment Screws



Figure 18 - Adjust Gap Setting

5 Troubleshooting

The following table is a list of common problems that may be encountered during installation. If this information fails to solve the problem, complete the Installation Review Form (See Section 6) and return to the local distributor or to Sonic for evaluation.

Table 5 - Troubleshooting

Problems / Symptom	Cause
Little or No Air Pressure	Verify blower wiring Verify blower rotation direction Verify correct belt installation Check / clean filter Incorrect blower pulley size
Inadequate Drying	Air knives too far from product Air knives not positioned correctly Low system pressure Incorrect air knife gap Incorrect blower pulley size
Excessive Noise	Air knives not staggered Need acoustical enclosure

6 Installation Review

INSTALLATION REVIEW – AIR KNIFE APPLICATIONS

The following is a series of questions to be answered and observations that must be made in order to evaluate any existing Sonic Blower installation.

A. Review prepared by: _____ Date: _____

B. End user name: _____

Address: _____

Contact: _____ Phone: _____

C. Did end user buy from: _____ Sonic Direct _____ Distributor _____ OEM

If OEM, specify name: _____

D. How many assemblies does the customer have: _____

E. Identify blower assemblies by:

Serial number	Model number	HP	Date installed

F. How does the customer identify the system?

Name, Line name/number, Location _____

G. Blower(s) installed _____ Inside customer/OEM's cabinet _____ Inside customer plant

_____ Inside Sonic supplied enclosure _____ Outside plant

H. With entire blower and related system running up to temperature, please take the following readings:

Running Amps at _____ at _____ Volts

Air knife pressure measured at slots = _____ H₂O

I. Verify direction of shaft rotation: are the pulleys clockwise and the cooling fan?

_____ Yes _____ No and corrected

J. If butterfly valve(s) are not fully open, please open to 100% and measure amps _____ and airknife _____ H₂O

K. Now, with all (if any) covers, blower enclosures, and access panels in place measure:

1. Ambient temperature of equipment location _____ °C/F

2. Ambient temperature inside of blower/motor enclosure if applicable _____ °C/F

3. Inlet temperature to blower (if not same as #2) _____ °C/F

4. Temperature inside air knife drying chamber _____ °C/F

L. Specify all related systems aspects

1. Does system have I.R. heat zone? _____

2. What is the temperature of the product/water prior to A/K? _____

3. Is moisture/air exhausted from A/K zone? _____

4. Is there any noticeable vibration on the blower housing _____

5. How many blowers, pumps, compressors or other motors are within the system? _____

6. Are there any vibration isolators between motors and mounting frame? _____

M. Blower Conditions:

1. Is the immediate area above, below, around blower/motor:
- | | |
|---|--------------------------|
| _____ Clean | _____ Normal Dirt |
| _____ Heavy Dirt | _____ Abrasive Materials |
| _____ Mildly Wet | _____ Washdown Area |
| _____ Contaminated with chemical or other? If so please describe: _____ | |
-

N. Belt Drive Conditions:

1. Blower Pulley _____ Good _____ Slightly worn
 _____ Heavy groove wear, how many grooves? _____
2. Motor Pulley _____ Good _____ Slightly worn
 _____ Heavy groove wear, how many grooves? _____
3. Existing Belt Tension with Cricket Tensioner= _____ lbs.
4. How many strands on belt? _____
5. How many belts has customer replaced, per blower during what period? _____ per _____
6. From whom is customer purchasing belts? _____
-

O. Blower Air stream Conditions: _____ Polyester _____ Paper Is element clean & dry? _____

What type of air filter element is used? _____

Visual inspection of the blower inlet and outlet shows:

- | | |
|-------------------------------------|---------------------------|
| _____ Very Clean | _____ Light dirt build up |
| _____ Heavy particle debris | _____ Corrosion/oxidation |
| _____ Oily substance/film | _____ Water droplets |
| _____ Heavy water trails and swirls | |

P. Application Background:

1. Does air knife perform as required? _____ Yes _____ No If no, describe why and what is the objective? _____
-

2. Air knife design: _____ Sonic XE _____ Sonic Round _____ Other Design _____ Sonic Air Collar

State the number of knives, length and slot with: _____

3. Are there hoses, piping or manifolds that might reduce performance? _____
 Describe: _____
-

4. Is/are air knife/air knives as close to product being dried as possible? _____ What is the distance? _____

5. Has maintenance been done to improve performance and/or longevity? _____

6. What type of maintenance and how often does customer perform? _____
-

7. What must be done to improve performance and or longevity? _____
-

8. Are blowers being operated above 125°F requiring water-cooling? _____

